

CHAPTER 2

GENERAL INFORMATION FOR SELECTION OF BATTERIES FOR PHOTOVOLTAIC SYSTEMS

Photovoltaic systems are designed to perform the following functions:

- Convert solar energy to direct current **electrical energy**
- Regulate the electrical energy output
- Feed the electrical energy into an external load circuit to perform work, or
- Store the electrical energy in a battery subsystem for later use.

Photovoltaic systems are designed for many applications varying in size and complexity. Some are isolated from ac power lines. Remote systems include navigational aids along coastlines; beacons on mountain peaks, **remote homes**, and isolated villages in developing countries. Some photovoltaic systems have ac power or **fossil fuel** generators as a source of auxiliary electric power. Systems are designed for water pumping stations, for supplying power to TV and communication equipment, village power, auxiliary power for heating and cooling private homes and industrial applications.

COMPONENTS AND FUNCTIONS

A block diagram of a typical system is shown in Figure 2-1 to identify the components and their functions. The key components are the solar panel, the voltage regulator, the storage battery, the dc-ac inverter (or dc to dc converter), and the load.

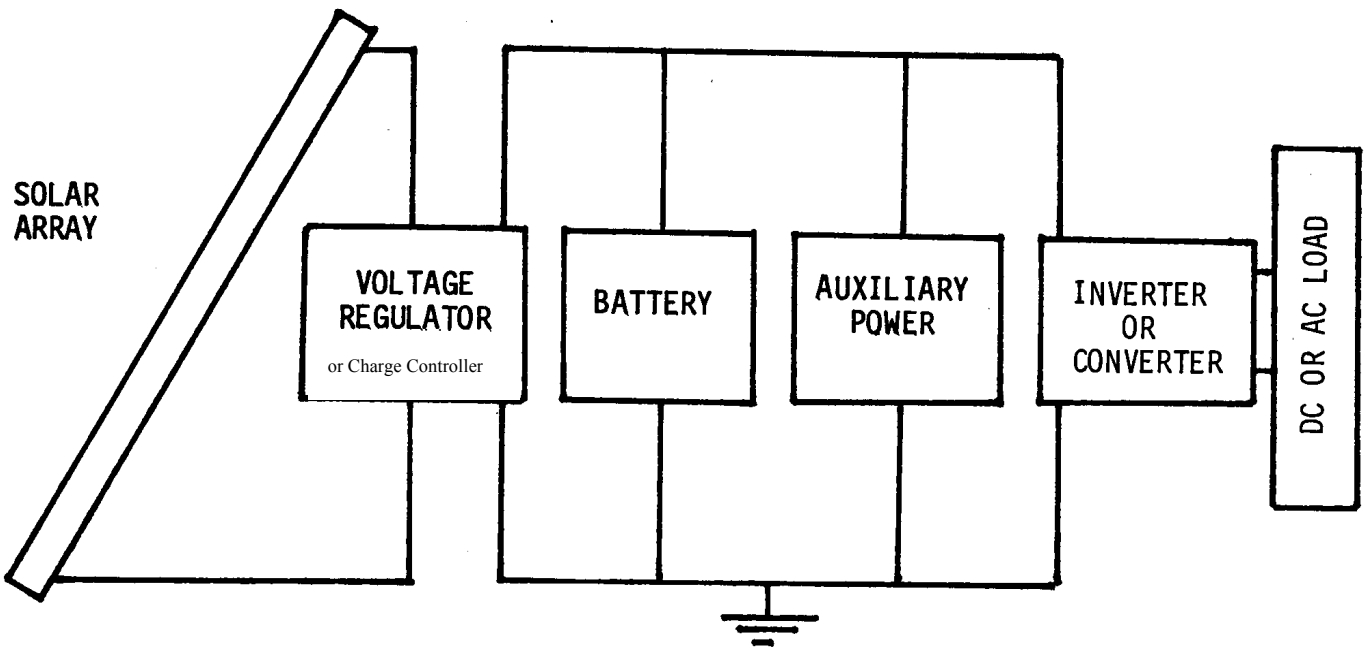

Figure 2-1 Components of Solar Photovoltaic System

Solar panels are an orderly arrangement of solid state photovoltaic cells in series and parallel strings which convert incident solar energy into direct unregulated current. Panel electrical performance is normally described by its characteristics delivered under maximum sunlight:

- Peak power
- Voltage at peak power
- Current at peak power
- Short circuit current
- Open circuit voltage

Incident sunlight, or insolation, varies during the day, **with elevation**, and with geographical location. Panel output therefore also varies and must be regulated by the **charge controller** to control the charging of the battery subsystem. Excessive **overcharging of a** battery is a major **cause of** short battery life.

The dc-ac inverter changes dc power from the solar panel or the battery to ac power to perform work in ac loads (motors, transmitters, lights, etc.). A dc-dc converter can be used if the load is designed for dc power.

At night and during continuing overcast days, the energy stored in the battery subsystem can be depleted. When the battery voltage drops below a predetermined value, the auxiliary dc power supply cuts in to carry the load and recharges the battery.

In the simplest stand-alone system, the only components which may appear to be needed are the solar module, the battery and the dc load. The battery is sized to accept the highest power output from the solar panel without overcharge damage.

In most cases, however, insolation is not that predictable, and the **array** output varies over such a wide range that **charge** regulators are needed and recommended to control charging current. A low voltage disconnect is also recommended to protect the battery from deep discharge.

The battery stores excess energy generated by the solar **array** during bright days of high insolation and discharges this stored energy back into the load at night or on overcast days. For a continuous power output capability, the battery is a very essential component. Batteries can be selected to give a **higher peak** output than the solar **array** to provide:

- High peak energy for starting motors or engines
- For opening and closing circuit breakers
- For steady power output for long periods of time

In addition, the battery can repeat these functions through many charge-discharge cycles within a wide temperature range during its long life. Correct battery selection and sizing is most important to the success of the solar photovoltaic system.

KEY ELEMENTS IN BATTERY SELECTION

Selection of the proper battery for a solar photovoltaic system requires a complete analysis of the battery discharge requirements. The kilowatt-hours of energy stored in the battery will depend upon the load requirements, the number of days of storage, the insolation patterns in the geographical area of the installation and the solar array output. Factors in sizing the battery are operating temperature variations, environmental temperature extremes and weekly/daily useage, the voltage regulator design, and the efficiency of the inverter.

The energy required to charge a battery will be the sum of the previous discharge energy output and the energy expended as work and excess heat during the recharge. Longer charge times and lower charge currents tend to increase charge efficiency. In lead-acid batteries, turn around energy efficiency can approach 85 percent. Shorter charge times and higher charge currents will sacrifice energy efficiency and battery life. Charge time and power available from the solar array must therefore be considered in selecting the battery type and size.

The analysis of the application requirements must include as a minimum the review of the following performance parameters:

- The minimum and maximum operating voltage of electronic equipment, battery and components of the load: i.e., the voltage window
- The power cycle including all sequences of charge and discharge
- The power output profile of the photovoltaic panel predicted at the site under the prevailing insolation patterns.
- **Seasonal and environmental variations.**
- **Availability and frequency of maintenance.**

Charging power at voltages up to the maximum voltages at top-of-charge **at operating temperature** required by the battery must be available from the voltage regulator for sufficiently long periods during each charge period to maintain the battery in the charged state. If charging voltages are set too low, recharge time will be greatly extended or, in the worst case, recharge will not be completed. **This is especially important with some types of sealed batteries.** The minimum voltage in the window will be the lowest voltage delivered by the battery during discharge, and/or the voltage at which auxiliary power will be introduced to the system to recharge the battery, or the voltage at which the battery will disconnect from the load. This voltage window determines the number of solar cells in series in the photovoltaic panel and the number of battery cells in series in the battery subsystem. **Nominal voltage standards in the industry (such as 6, 12, 32, 36, 48, etc. volts) are preferred**

A study of the power requirements of the system **loads on an annual basis should be completed to assess the array and battery sizing to meet the desired system availability and reliability in conjunction with any backup system employed.**

A corresponding study of the photovoltaic panel output must establish the sequential pattern of power output and duration expected on site for the full period of system operation for not less than one year. Seasonal (and yearly) variations may show, as in Figure 2-2, that excess power may be expected during high insolation months but that, in some months, the power required by the anticipated load can exceed power available from the solar panel. Unbalance of power requirements of this kind must be corrected by increasing the panel size, by power conservation in the load, or by use of an auxiliary power source.

From the analysis above. considerations must establish:

- The size of the photovoltaic panel/array required to provide the energy for the load and for recharging the battery subsystem
- The recharging time and power available
- The size of the battery required for energy storage, i.e., number of cells in series and parallel, the individual cell capacity, the subsystem storage energy in kilowatt-hours and capacity in ampere-hours.

Battery cell type, plate and separator designs must then be selected in consultation with the sales engineers representing the battery supplier. Cell design must match the highest charge and discharge rates and the extremes in operating temperature predicted for the battery under conditions at each site. The battery supplier must provide operating voltage data to assure the system designer that the required capacities are delivered within the specified acceptable voltage range, over the expected range of environmental conditions.

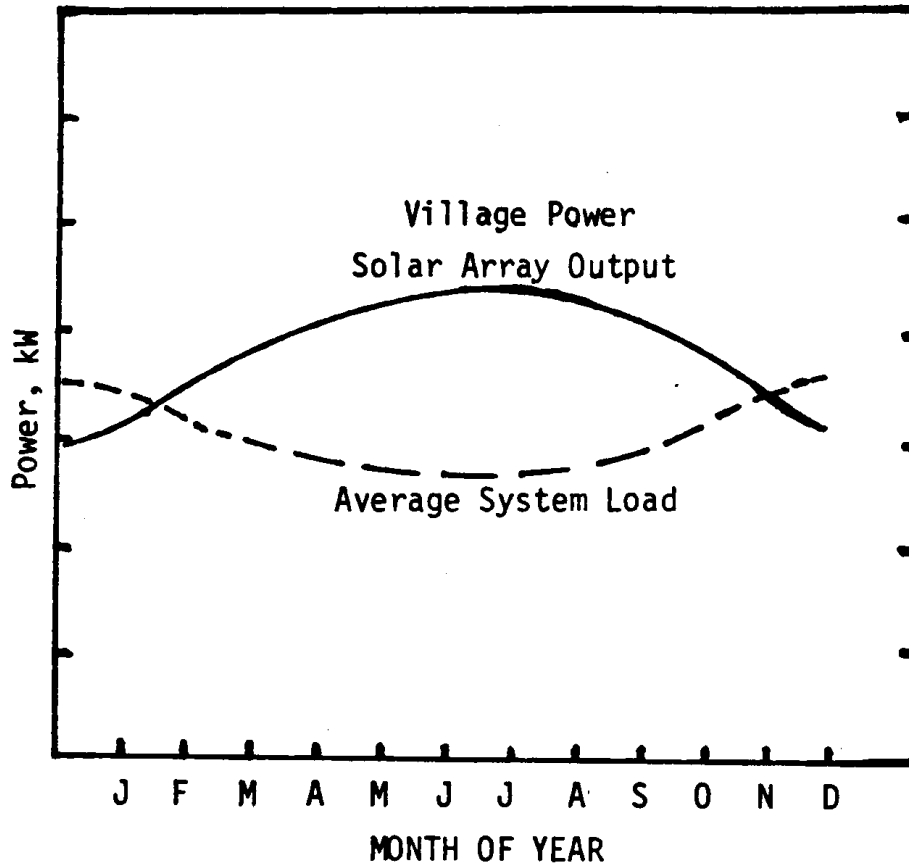

Figure 2-2 Solar Array Ys. System Load Power Requirement (2-1)

for each load period in the duty cycle. The battery supplier can select from the product line cells with most desirable number of plates, plate thickness, active material density, plate grid design, **specific gravity** and separator system to control cell and battery performance.

Battery maintenance must also be considered. To visit remote installations for the purpose of system or battery maintenance can require a substantial transportation and labor cost. Maintenance-free or reduced maintenance batteries are attractive in these applications if other performance attributes are also demonstrated. Replacement of water loss from overcharge electrolysis of battery electrolyte is the major task of maintenance in vented batteries, both lead-acid and nickel-cadmium. Other tasks are keeping intercell and inter-row battery connections tight

and the battery clean and dry. Maintenance can be scheduled from a knowledge of the overcharge in the duty cycle and the number of cycles per week.

Battery operating life in the solar PV system is a function of the operating temperature, the duty cycle, **the depth of discharge**, the charge control and the cell design. Significantly higher average operating temperature decreases life, and the number of **available** charge-discharge cycles decreases with increasing depth of discharge.

In general, longer-life batteries have a higher initial cost. Replacing a battery, especially a very large array of cells, can be a substantial element in storage battery costs. Economic studies should be made to reflect the sum of initial battery price, installation costs, operating and maintenance costs, and the cost of replacement. The overall price of a long-life battery may be less than the price of two shorter-life batteries when all factors are considered. The battery manufacturer **or supplier** can provide an estimate of the operating life of each battery type on the market when the operating time-temperature and duty cycles are well known.

REFERENCES:

- 2-1 B. L. Grossman, B. L. Brench, L. L. Bucciarelli, F. J. Solman, Simulation of the Performance of a 100 kW Peak Photovoltaic System, Massachusetts Inst. of Tech., Lexington, Mass. 1980, COO-4094-71.